

# Data Sheet

## Dynamic Impact Bed

Contact Details	
Name:	Contact No:
Company :	Email:
Address :	

Functional Specifications			
Conveyor.		Material Information	
Conveyor No.		Product type	
Belt width (mm)		Max lump size	
Belt speed (m/sec)		Avg. lump size	
Trough angle		Specific	
Troughing idler brand / Model		TPH	
Roller dia. (mm) & type e.g. impact		Free fall height	

or complete below:

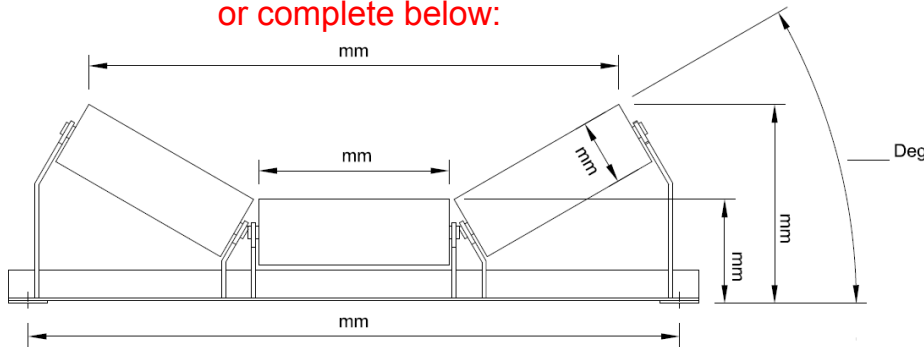

Required Length of new Impact Bed

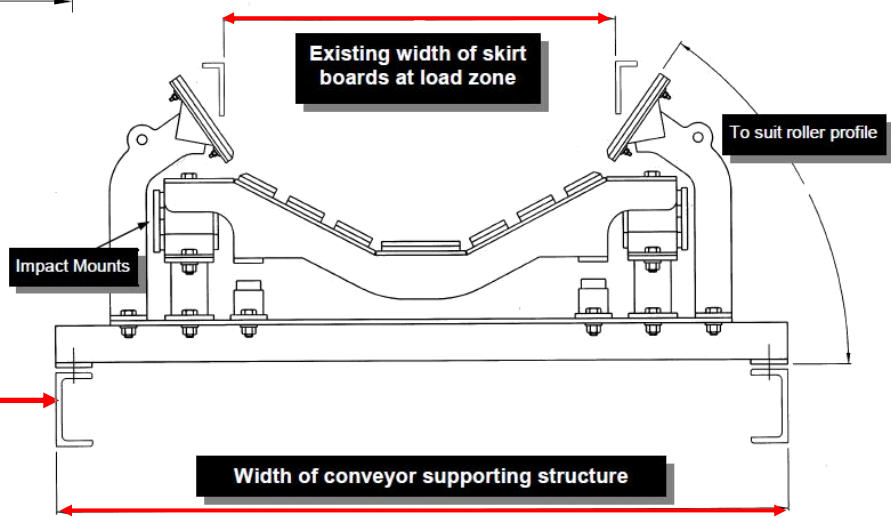
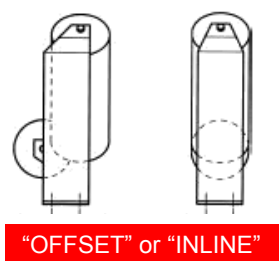

Describe shape, size and orientation.